

PEM 6320 SERIES

OVERFLOW STAND PIPE GRATE 3", 4" & 6" PVC 75mm, 110mm & 160mm

PEM 6320 Series Overflow Grates are designed for projects that incorporate a remote Reservoir Tank, to keep the waterdepth in the accessible pool to a minimum, the extra surface area permits largest possible water absorption, while not protruding above waterlevel. Vandal resistance is built into these grates. PEM 6320 Series Overflow Grates are made of cast bronze, brass and stainless steel fitted, with 'O'ring seal.

The '-1' Grate is screwed on to brass or stainless steel pipe, this method is preferred in public locations with heavy pedestrian access especially in the winter when exposed plastic pipe gets brittle. The '-2' Grate is installed onto DIN 19 534 PVC pipe, with an internal 'O' ring sealing the connection, set screws secure the grate.

The total pipe manufacturing to the Reservoir Tank must be sized in accordance with zero gravity pressure. The suggested flow rates are for 10mm overflow height over lip of grate. The Reservoir Tank used for storing the circulating water must be equipped with an automatic water make up device & overflow. The pump discharge must include a flow switch to shut off the pump in case of no-flow. This is extremely important as public water displays may be subject to foam attacks by juveniles.

#611-1180



PEM 6323-2



PEM 6326-2

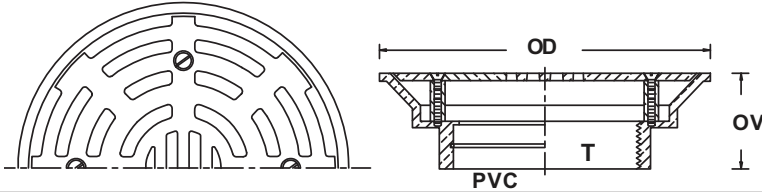

#	PEM	T	PVC mm	OD mm	OV mm	Flow* L/min.	Flow* m³/hr.
611-0831	6323-1	3"		220	64	172	10.3
611-0832	6323-2	-	75	220	64	172	10.3
611-0833	6324-1	4"		240	64	187	11.1
611-0834	6324-2	-	110	240	64	187	11.1
611-0835	6326-1	6"		290	89	227	13.6
611-0836	6326-2	-	160	290	95	227	13.6

* : 10mm Overflow height over lip of grate.

PEM 6321 ALL CAST BRONZE GUTTER DRAIN WITH GROUT FRAME, 1 1/2" NPT/ SP

PEM 6321- 61, #611-1181, with Surface Flange
PEM 6321- 62, #611-1182, with Surface Membrane Clamp



PEM 6321 is made of cast bronze, stainless steel fitted.

Open grating area: 40.3 cm2-6.25 Sq. In.

Suggest Max. Flow Rate: 45 L/min-12 USGPM with 300mm/12" head

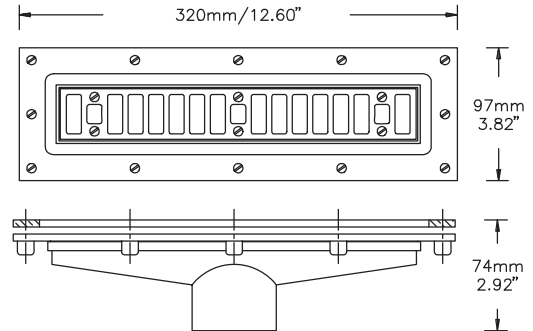

PEM 6321-60

PEM 6338 VACUUM FITTING 1 1/2" X 1 1/2" NPT/BSP

PEM 6338 are made of cast bronze & brass, stainless steel fitted.

For Sub Surface Liner Flange, Clamp & Tile Mask: See PEM 6345

#	PEM	DESCRIPTION
611-2100	6338	Standard Fitting
611-2110	6338-61	w. Surface Flange
611-2120	6338-62	w. Surface Liner Clamp
611-2150	6338-65	w. Subsurface Flange
611-2160	6338-66	w. Subsurface Liner Clamp
611-2103	6338-TM	Tile Mask

78mm/3.07" 110mm/4.33"



PEM 6338 & Plug



PEM 6338-62 with Plug

